

LED T8 TUBE LAMPS - Oval SERIES PRODUCT SERIES DATASHEET



LED T8 Oval Tube Lamps



88Light LED T8 Oval Tube series is ideal for Home, Commercial and Public Lighting. 100% retrofit with more than 100Lumen per watt efficiency Epistar chips provides a high anti-static resistance and unique brightness distribution.

Applications:



Restaurant



Office



Residence



Living Room

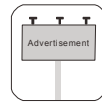

Advertising



Hotel



School



Railway Station

PRODUCT FEATURES

- Aluminum alloy Tube, light weight and more safer when delivery.
- Milk Cover, the light is uniform like traditional glass tube.
- High efficiency, save more energy than traditional fluorescent tube.
- Large input of voltage from AC90-265V, quick start without delay.
- Low light decay to keep good maintains.
- Good light without UV, IR to avoid harmful to human eyes.
- Low heat emit to the environment.
- WW 2800K/3000K, NW 4000K, CW 6500K, Red, Green, Blue, Yellow, Pink and Purple color options.
- It can light up to 50,000 hours (based on 14 hours daily usage).
- Double side connection, single side bridged or non-bridged options upon request.
- Rotatable and non-rotatable cap options.
- CE for EMC and LVD approved and RoHS compliant.



LED T8 TUBE LAMPS - Oval SERIES
 PRODUCT SERIES DATASHEET



ILLUMINANCE DIAGRAM

Product Luminance:

10 Watts

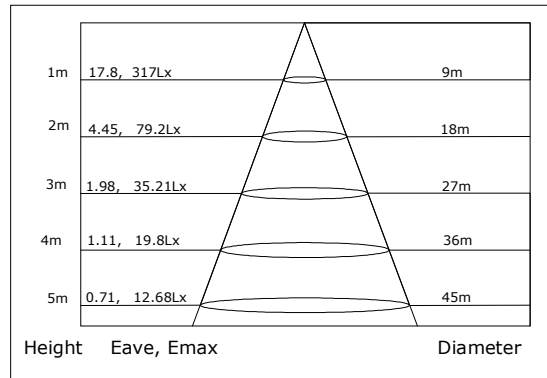
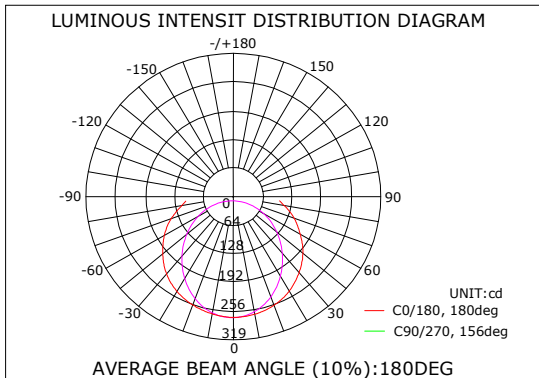

12 Watts

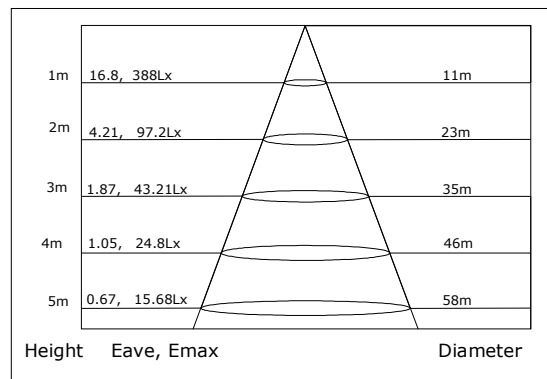
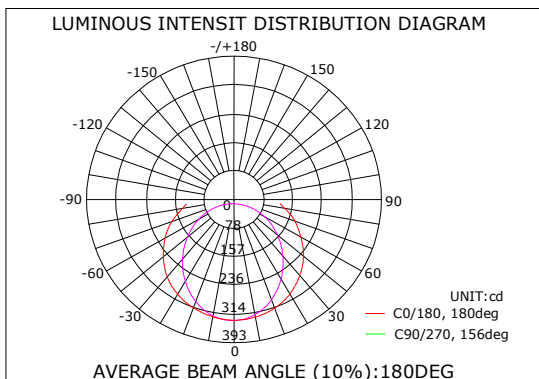

18 Watts

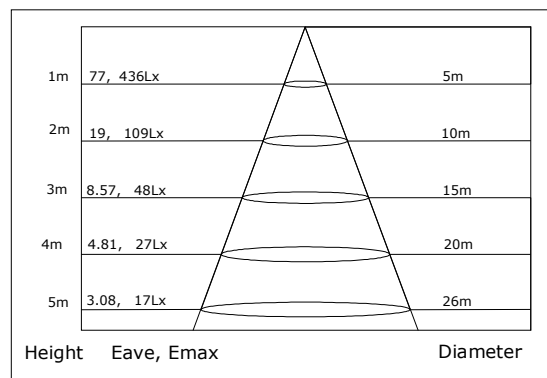
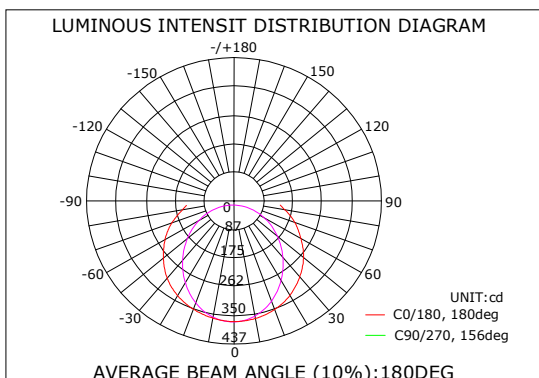

LED T8 TUBE LAMPS - Oval SERIES
 PRODUCT SERIES DATASHEET



ILLUMINANCE DIAGRAM

Product Luminance:

24 Watts

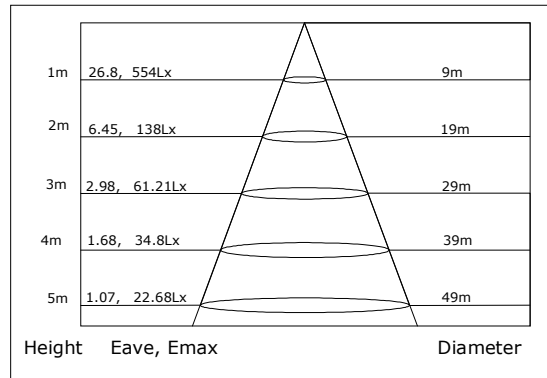
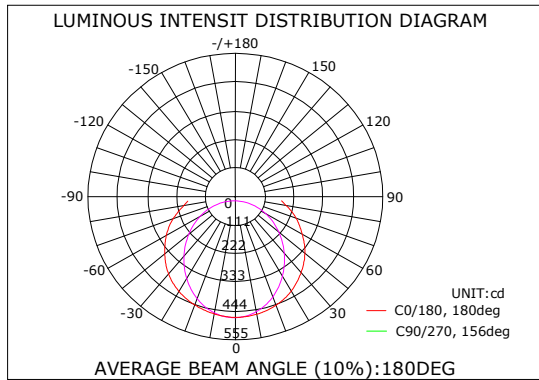

38 Watts

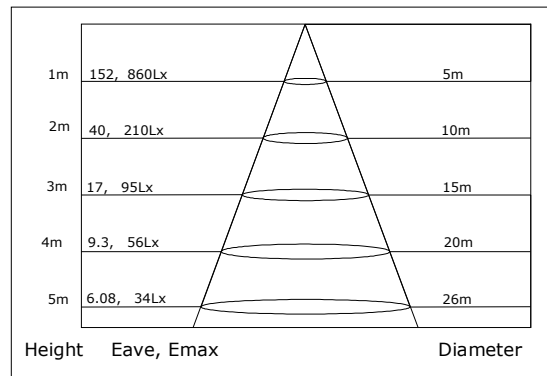
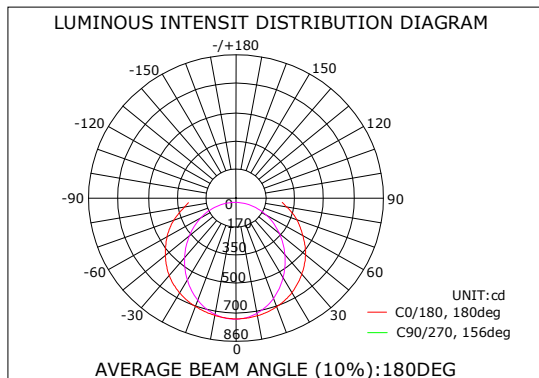

PRODUCT DIAGRAM

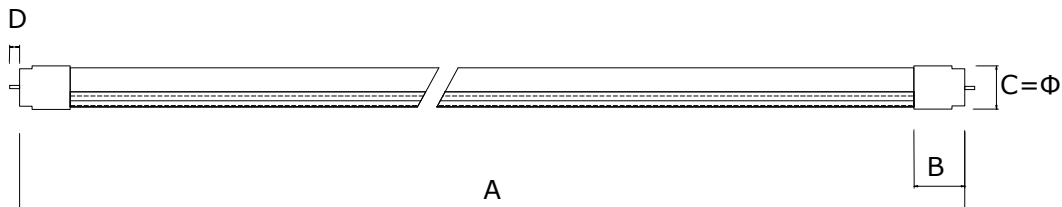

LED T8 TUBE LAMPS - Oval SERIES
PRODUCT SERIES DATASHEET



PRODUCT DIAGRAM

Product Name	A [mm]	B [mm]	C [mm]	D [mm]
88L-LT-10W-60T8-FA	600	36	30	7
88L-LT-12W-90T8-FA	900	36	30	7
88L-LT-18W-120T8-FA	1200	36	30	7
88L-LT-24W-150T8-FA	1500	36	30	7
88L-LT-38W-240T8-FA	2400	36	30	7

Note 1: Absolute ratings @ 25°C.

Note 2: Tolerance of measurement of diameter intensity±2.

TECHNICAL DATA

Electrical characteristics^{1, 3, 4}:

Product Name	Operating ⁴ Voltage [Vac]	Frequency [Hz]	Power [w]	Power Factor	LED Information	Base
88L-LT-10W-60T8-FA	90 ~ 265	50 / 60	10	>0.92	120pcs SMD3014	G13
88L-LT-12W-90T8-FA	90 ~ 265	50 / 60	12	>0.92	126pcs SMD3014	G13
88L-LT-18W-120T8-FA	90 ~ 265	50 / 60	18	>0.92	192pcs SMD3014	G13
88L-LT-24W-150T8-FA	90 ~ 265	50 / 60	24	>0.92	220pcs SMD3014	G13
88L-LT-38W-240T8-FA	90 ~ 265	50 / 60	38	>0.92	380pcs SMD3014	G13

Note 1: Absolute ratings @ 25°C.

Note 3: Operating Temperature -20~+45° C; Storage Temperature -30~+60° C.

Note 4: The input voltage maybe 90-165Vac/165-265Vac or 90-265Vac.

LED T8 TUBE LAMPS - Oval SERIES
PRODUCT SERIES DATASHEET



TECHNICAL DATA

Optical Characteristics^{1, 5}:

Part number	Color	Color Temp. [°K]	Luminescence ⁵ [lm]	CRI (Ra)	Beam Angle [°]
88L-LT-10W-60T8-FA-CW	Cold White	6000	1200	>80	200
88L-LT-10W-60T8-FA-NW	Nature White	4000	1100	>80	200
88L-LT-10W-60T8-FA-WW	Warm White	3000	1000	>80	200
88L-LT-12W-90T8-FA-CW	Cold White	6000	1500	>80	200
88L-LT-12W-90T8-FA-NW	Nature White	4000	1400	>80	200
88L-LT-12W-90T8-FA-WW	Warm White	3000	1300	>80	200
88L-LT-18W-120T8-FA-CW	Cold White	6000	1800	>80	200
88L-LT-18W-120T8-FA-NW	Nature White	4000	1700	>80	200
88L-LT-18W-120T8-FA-WW	Warm White	3000	1600	>80	200
88L-LT-24W-150T8-FA-CW	Cold White	6000	2400	>80	200
88L-LT-24W-150T8-FA-NW	Nature White	4000	2300	>80	200
88L-LT-24W-150T8-FA-WW	Warm White	3000	2200	>80	200
88L-LT-38W-240T8-FA-CW	Cold White	6000	3800	>80	200
88L-LT-38W-240T8-FA-NW	Nature White	4000	3700	>80	200
88L-LT-38W-240T8-FA-WW	Warm White	3000	3600	>80	200

Note 1: Absolute ratings @ 25°C.

Note 5: Tolerance of measurement of luminous intensity±6%.

LED T8 TUBE LAMPS - Oval SERIES
 PRODUCT SERIES DATASHEET



PRODUCT INSTALLATION [Standard LED tube with 2 sides connection]

Standard tube with double side connection, replacement when electronic ballast:

If lighting fixture's wire connection is Electronic ballast, installation as bellow:

- Step 1. Remove the traditional fluorescent tube from the lighting fixture.
- Step 2. Take out the electronic ballast from the lighting fixture.
- Step 3. After take out the ballast, there will have two wires. One wire connects to right side and another wire connects to left side.
- Step 4. Install LED tube light into lighting fixture.

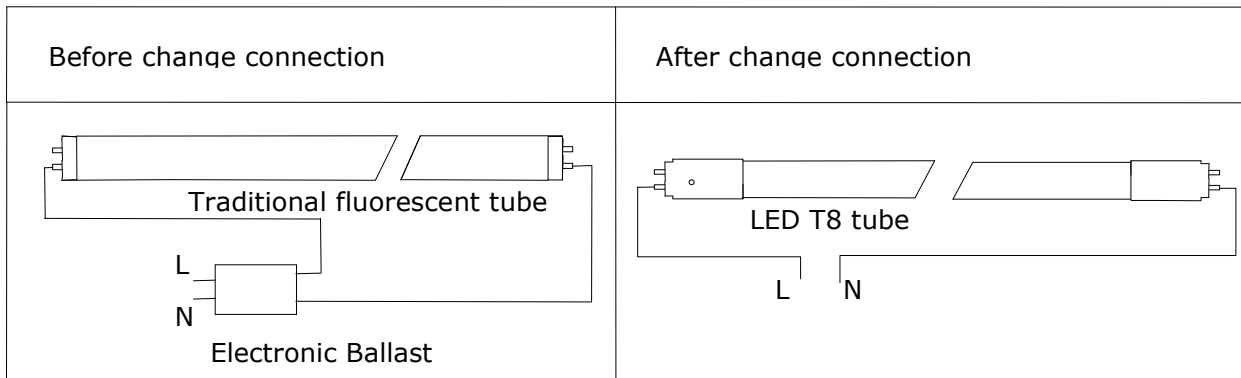

Standard tube with double side connection, replacement when inductive ballast:

If lighting fixture's wire connection is inductor ballast, installation as bellow:

- Step 1. Remove the traditional fluorescent tube from the lighting fixture.
- Step 2. Take out the starter and inductor ballast from the lighting fixture.
- Step 3. After take out the ballast, there will have two wires. One wire connects to right side and another wire connects to left side.
- Step 4. Install LED tube light into lighting fixture.

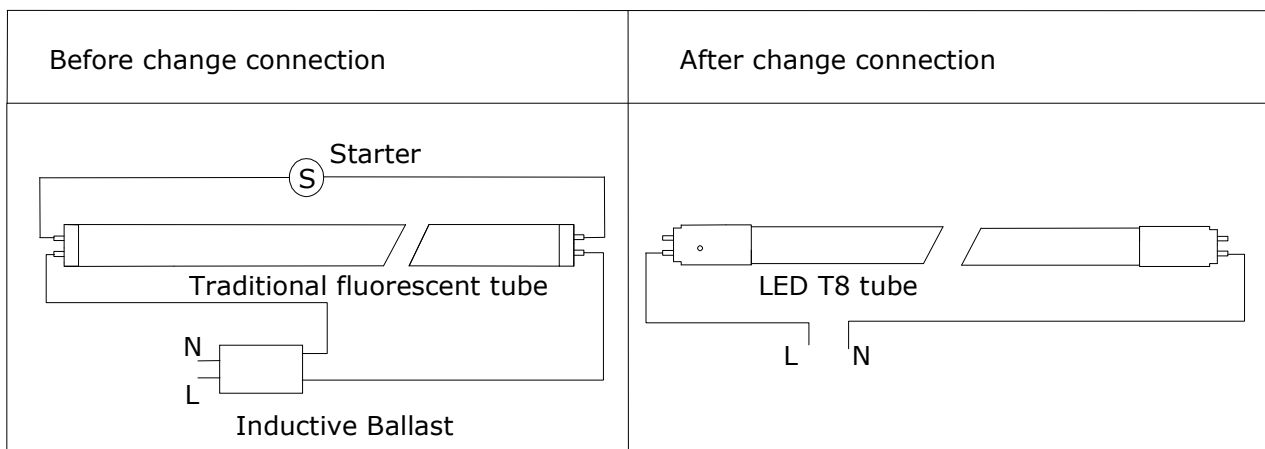

LED T8 TUBE LAMPS - Oval SERIES
 PRODUCT SERIES DATASHEET



PRODUCT INSTALLATION [**Optional** single side *NON-BRIDGED* LED tube]

Precaution: Switch off power before doing any works. Confirm if your LED tube is the non-bridged type, a bridged LED tube used in a fixture designed for NON-BRIDGED LED tubes have a risk of short circuit.

NON-BRIDGED LED tube replacement when Electronic ballast:

If lighting fixture's wire connection is electronic ballast, installation as bellow:

Step 1. Remove the traditional fluorescent tube from the lighting fixture.

Step 2. Take out the electronic ballast from the lighting fixture.

Step 3. After take out the ballast, there will have two wires. Both wires connect to the indicated SINGLE side it cold be label indicated, different color than white or longer cap with clip; one cable goes to N and the other to the L.

Step 4. Install LED tube light into lighting fixture.

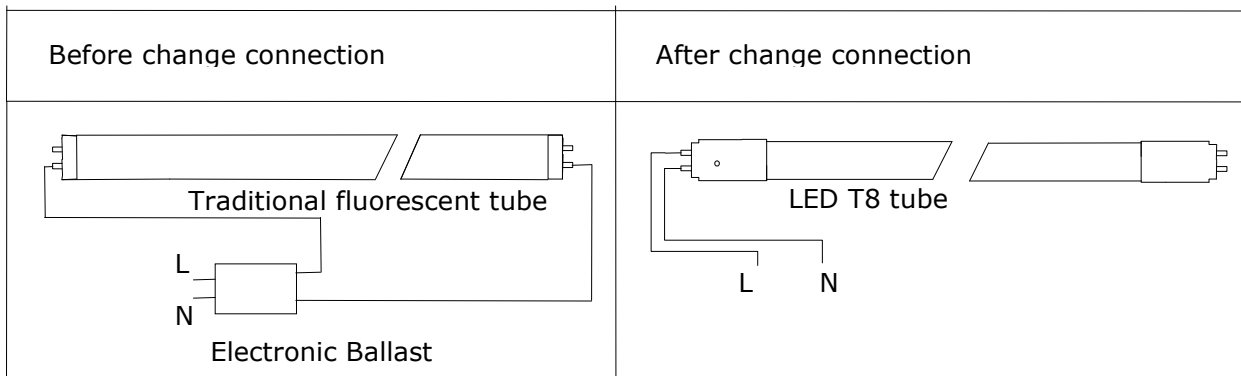

NON-BRIDGED LED tube replacement when inductive ballast:

If lighting fixture's wire connection is inductor ballast, installation as bellow:

Step 1. Remove the traditional fluorescent tube from the lighting fixture.

Step 2. Take out the starter and inductor ballast from the lighting fixture.

Step 3. After take out the ballast, there will have two wires. Both wires connect to the indicated SINGLE side it cold be label indicated, different color than white or longer cap with clip; one cable goes to N and the other to the L.

Step 4. Install LED tube light into lighting fixture.

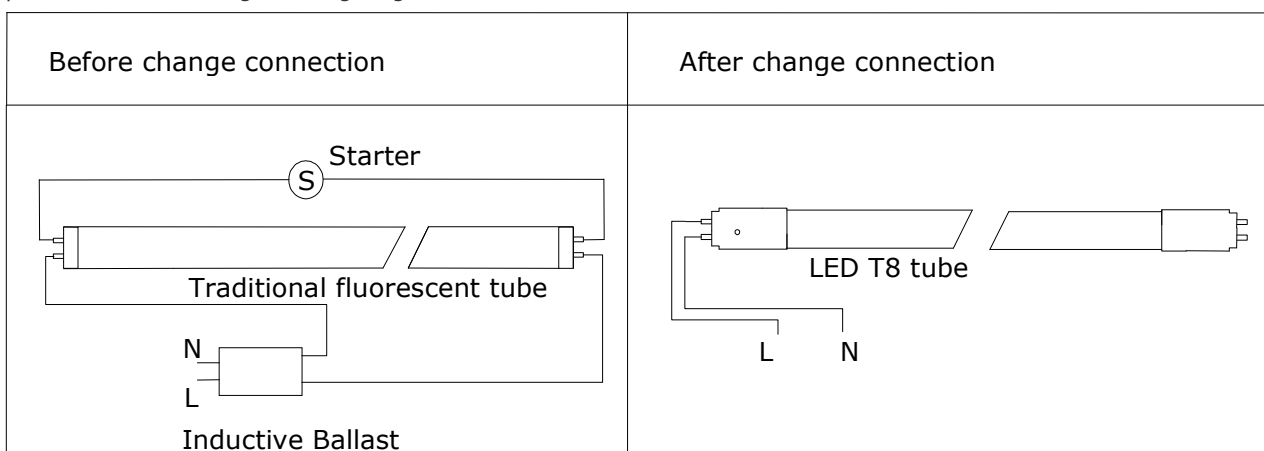

LED T8 TUBE LAMPS - Oval SERIES
 PRODUCT SERIES DATASHEET



PRODUCT INSTALLATION [**Optional** single side *NON-BRIDGED* LED tube]

ONE SINGLE SIDE NON-BRIDGED TUBE CONNECTION

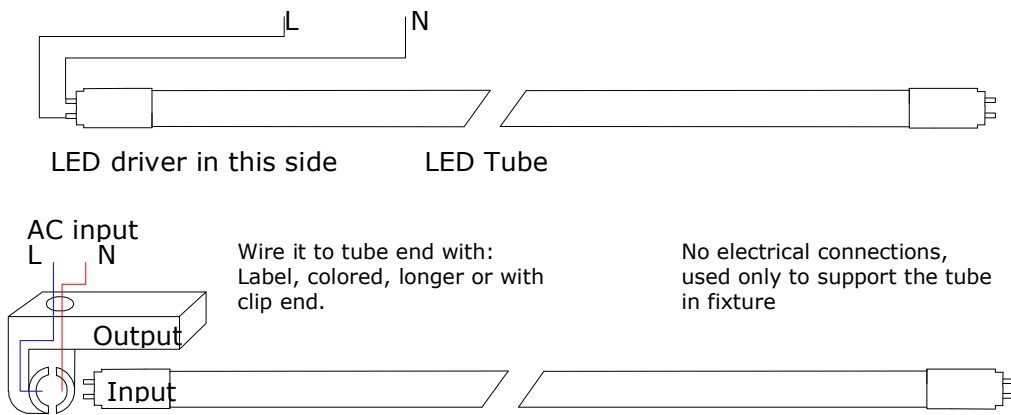

Please note or add a warning label after the product has been installed to indicate the type of single side connection LED tube that can be used. This data sheet connection diagram shows only the non-bridged single side tube option, for bridged tubes please consult 88Light.

Recommended fixture caution label:



LED T8 TUBE LAMPS - Oval SERIES
 PRODUCT SERIES DATASHEET



PRODUCT INSTALLATION [**Optional** single side *BRIDGED* LED tube]

Precaution: Switch off power before doing any works. Confirm if the tube is the bridged type, non-bridged single side LED Tubes will not work in a fixture designed for bridged LED tubes.

BRIDGED LED tube replacement when Electronic ballast:

If lighting fixture's wire connection is electronic ballast, installation as bellow:

Step 1. Remove the traditional fluorescent tube from the lighting fixture.

Step 2. Take out the electronic ballast from the lighting fixture.

Step 3. After take out the ballast, there will have two wires. Both wires connect to the indicated SINGLE side it could be label indicated, different color than white or longer cap with clip; one cable goes to N and the other to the L.

Step 4. Install LED tube light into lighting fixture.

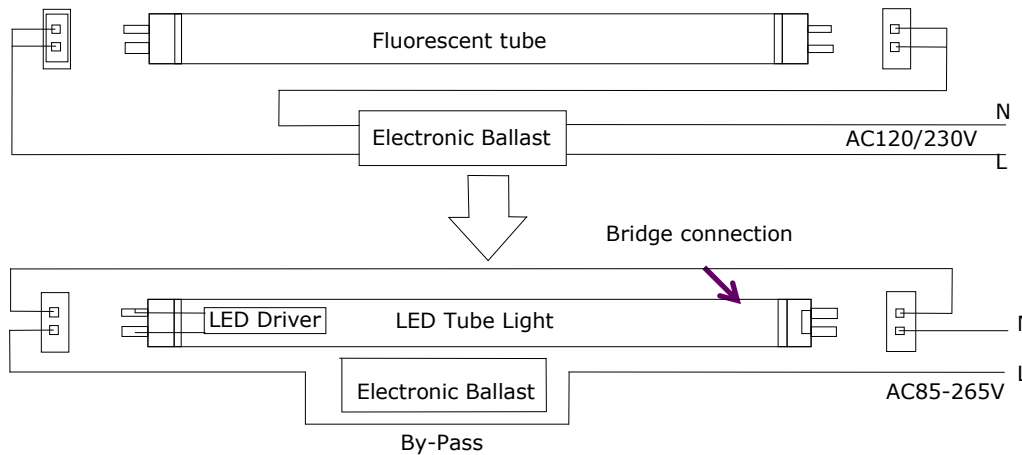

BRIDGED LED tube replacement when inductive ballast:

If lighting fixture's wire connection is inductor ballast, installation as bellow:

Step 1. Remove the traditional fluorescent tube from the lighting fixture.

Step 2. Take out the starter and inductor ballast from the lighting fixture and by-pass it as shown by the dotted line, OR replace the starter with a FUSE as shown by the solid line.

Step 3. Install LED tube light into lighting fixture.

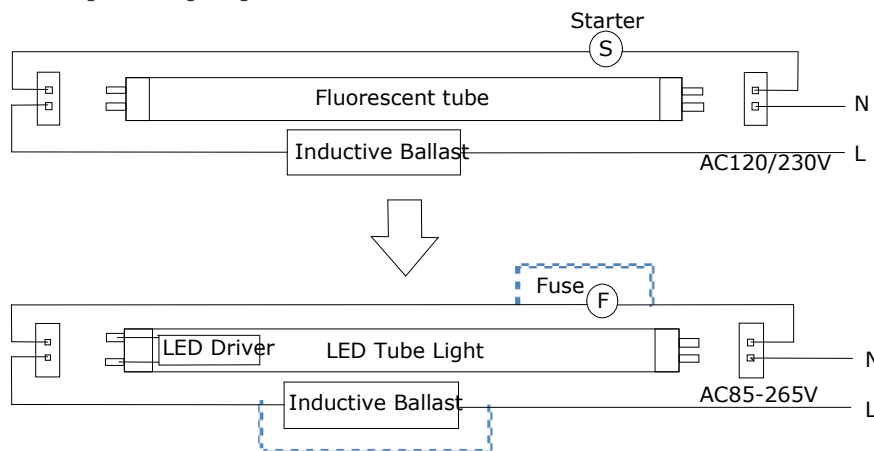

LED T8 TUBE LAMPS - Oval SERIES PRODUCT SERIES DATASHEET



SAFETY

1. **Always** consult a qualified, licensed electrician prior to the installation of this product.
2. **Always** ensure that all components are joined properly before they are installed.
3. LED tube and all of its components must not be subjected to mechanical stress.
4. If any doubt about the installation or use of this product, consult a competent electrician.
5. Don't use it if aluminum of the tube has any damage or distortion. Otherwise, the product or the installation might not be sufficiently safe!
6. 88Light T8 TUBE LAMPS FG Series, have 3 different options, one is **ONE SINGLE SIDE NON-BRIDGED** LED Tube, the other **ONE SINGLE SIDE BRIDGED** LED tube is the standard **TWO SIDE CONNECTION** LED Tube .please identify the connection type and side before starting the installation.
7. Switch off power of the mains supply or respectively of the connection lead before doing any works.
8. Assembly must not damage or destroy conducting paths.
9. Make sure that the product is mounted on a stable, even and tilt-fixed background.
10. Keep away from direct sunshine and high temperature.
11. LED products are continuously being improved upon in ever-shortening manufacturing cycles. LED color temperature (kelvin), lumen output, and product appearance can change from order to order. Please note that variation in color temperature (kelvin) is commonly +/- 250k and brightness (lumens) is +/- 10%.
12. Indoor use only.

PACKING:

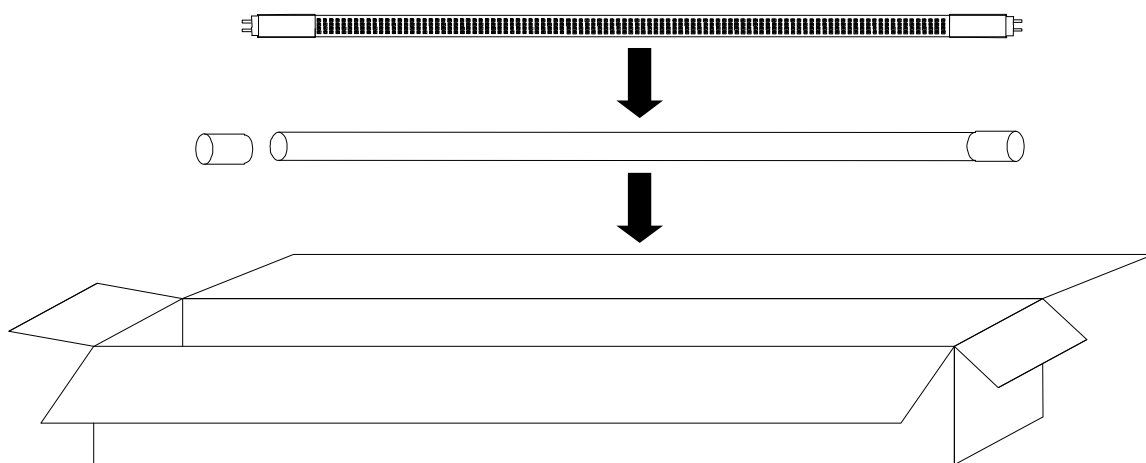

LED T8 TUBE LAMPS - Oval SERIES
PRODUCT SERIES DATASHEET



PACKING:

Product Name	Outer Carton Size (L×W×H)[cm]	Qty/Carton [pcs]	Gross Weight ⁴ [Kg]
88L-LT-10W-60T8-FA	65.5×22×23	25	6.6
88L-LT-12W-90T8-FA	95.5×22×23	25	10.5
88L-LT-18W-120T8-FA	125.5×22×23	25	12.6
88L-LT-24W-150T8-FA	155.5×22×23	25	15.8
88L-LT-38W-240T8-FA	245.5×22×23	25	24.5

Note 6: the package information is only for reference.

OTHER 88Light PRODUCTS:

For more information about 88Light products, or to use our online energy saving calculation software please visit our website

www.88light.com

DISCLAIMER:

88Light reserves the right to modify the design of our products as part of the company's program of continuous improvement. 88Light cannot guarantee to match existing installed product for subsequent orders or replace the product exactly to match the product you are replacing in product appearance, color, or brightness. Specifications are subject to change without notice.